



QUEEN ROLLER BLIND

INDOOR TECHNICAL BLINDS

QUEEN IS THE TRUE QUEEN OF ROLLER BLINDS.

ONE OF A KIND, QUEEN ROLLER BLIND COMBINES AN INNOVATIVE DESIGN WITH A SYSTEM ABLE TO SHADE AN AREA UP TO 10 M WIDE WITHOUT ANY TYPE OF BENDING.

IT IS THE IDEAL SOLUTION FOR OFFICES AND HOTELS.

MAXIMUM SUGGESTED SIZE: 10 M X 3 M

Box

QUEEN ALUMINIUM BOX WITH A FRONTAL INSPECTION WITH CRADLE TO SUPPORT THE ROLLER; GALVANIZED IRON END CAPS COATED AS THE ALUMINIUM STRUCTURE.

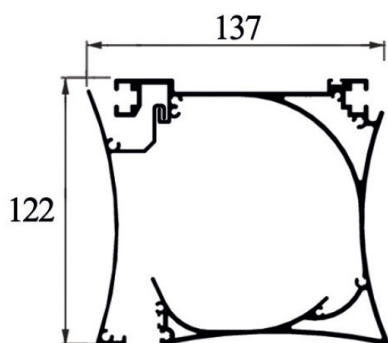

MOUNT

CEILING MOUNT WITH BRACKETS.

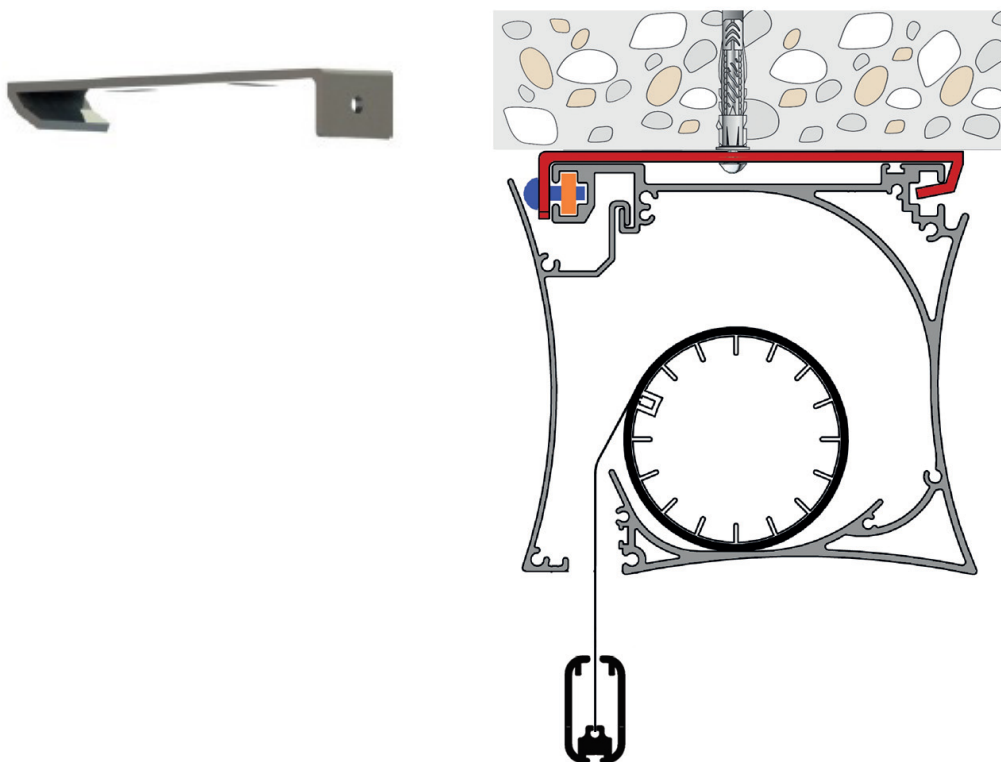

EASY MAINTENANCE SYSTEM

ALUMINIUM ROLLER TUBE Ø 63 AND EASY ZIP BOTTOM BAR WITH ZIP HOUSING.

ZIP IS WELDED ON 2 FABRICS SIDES. IT IS VERY IMPORTANT BECAUSE IT SPEEDS UP ASSEMBLY OPERATIONS AS ANY FABRIC REPLACEMENT / MAINTENANCE.



BOTTOM BAR WITH ZIP HOUSING

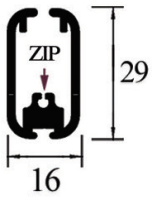



CONTROL

MOTOR CONTROL WITH WIRED DRIVES OR ELECTRONIC SETTING WITH REMOTE CONTROL.
AVAILABLE MOTORS ARE CHERUBINI, SOMFY AND GAPOSA.

FABRICS

VARIOUS FABRIC ARE USED IN QUEEN SYSTEM: SHADING OR BLACKOUT.

WELDING

ALL FABRICS ARE HORIZONTALLY WELDED.

COATING AND SCREWS

ALL ALUMINIUM PROFILES UNDERGO AN OPEN-PORE ANODIC OXIDATION PRETREATMENT.
THEN, THE POWDER COATING ON THE ALUMINIUM HAS HIGH MECHANICAL PROPERTIES AND INCREASE PROTECTION AGAINST CORROSION AND AGGRESSIVE ATMOSPHERE.
STAINLESS STEEL SCREWS.

Garattoni

LIVING | INNOVATION

GARATTONI DARIO DI R.I.

VIA DEL SALICE, 8 - 47822 SANTARCANGELO DI ROMAGNA (RN)

TEL. 0039.0541.625648

WWW.GARATTONIDARIO.COM - INFO@GARATTONIDARIO.COM

